

# X-Band Solid-State Power Amplifier

## DPXB8400R

Using technology developed for ModuMAX™ amplifiers, this rack-mount SSPA offers an output power of 400 watts across the standard 7.90–8.40 GHz satellite uplink band. The SSPA incorporates a modular architecture that includes the RF modules, power supplies, logic, fans, and front panel assembly. The amplifier is designed for reliable service in fixed and mobile applications.

### Features

- 400 W saturated output power
- Digital gain adjustment (20 dB range)
- Forward and reflected power monitoring
- Microprocessor-based monitor and control
- Serial interface (RS-232/-422/-485) standard
- 10 Base-T network interface (SNMP, HTTP)
- RF input and output sample port
- Integral 1:1 redundancy control

### Applications

- Single-thread SSPA
- Redundant systems (1:1, 1:2)
- Fixed installations
- Mobile terminals
- Government and Military systems

### Accessories

- RCP-2001 remote panel

### Block Diagram

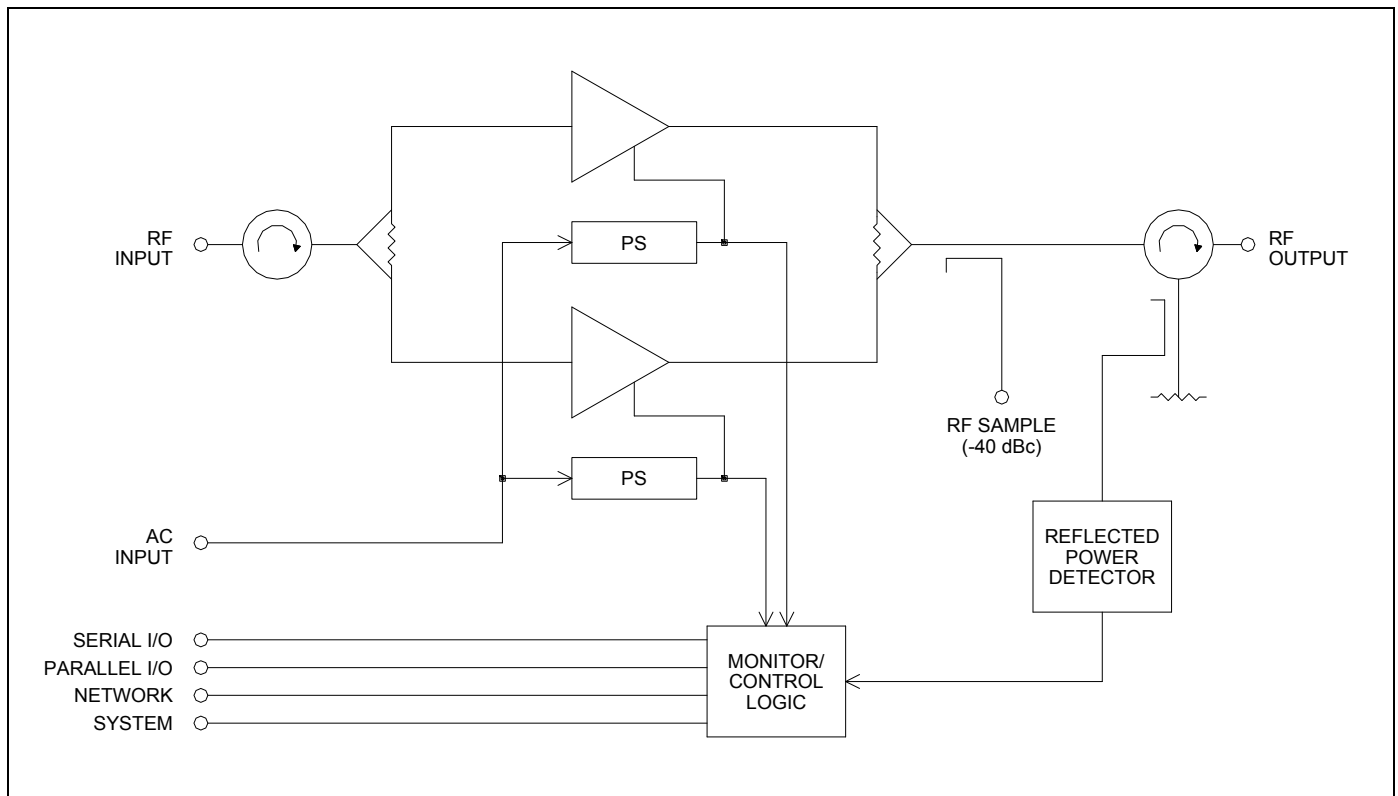

## Specifications

Parameter	Notes	Min	Nom/Typ <sup>†</sup>	Max	Units
Frequency Range		7.90		8.40	GHz
Gain, at maximum gain setting	Standard	67			dB
Gain Adjust Range	Digital, 0.1 dB steps	20			dB
Gain Flatness	Full band Per 40 MHz			±1.0 ±0.3	dB dB
Saturated Power Output			+56.0 (400)		dBm (W)
Power Output at 1 dB compression (P <sub>1 dB</sub> )		+55.2 (335)			dBm (W)
Two-tone Intermodulation	At 3 dB total backoff from 1 dB compression point		-30	-25	dBc
Group Delay	Linear Parabolic Ripple			0.03 0.003 1.0	ns/MHz ns/MHz <sup>2</sup> ns p-p
AM/PM Conversion	At P <sub>1 dB</sub>		2.5	3.5	°/dB
VSWR	Input Output		1.25 1.20	1.30 1.30	:1 :1
RF Sample Ports	Input Output		-10 -40		dB dB
Connectors	RF Input RF Output Sample Ports Serial I/O Parallel I/O System RCP Link Network Power		Type N Female CPR112G Waveguide Type N Female 9-pos D-sub Female, mate supplied 25-pos D-sub Male, mate supplied 15-pos D-sub, Male 9-pos D-sub, Male RJ-45 Jack 4-pos CE05, mate supplied		
Power Requirements	Voltage Frequency Power Power factor corrected	47	90–135 or 180–270 1900 0.98	63 2100 <sup>A</sup>	Vac Hz W
Cooling System			Forced air		
Operating Temperature Range	Ambient air temperature	0		+50	°C
Dimensions	See outline drawing		8.75 H x 19 W x 27.88 D 222 H x 483 W x 708 D		inches mm
Weight	Approximate		93 (42)		lb (kg)

<sup>†</sup> When there is only one value on a line, this column is a nominal value. Otherwise it is a typical value. Typical values are intended to illustrate typical performance, but are not guaranteed.

<sup>A</sup> Cold start, at -40 °C and P<sub>OUT</sub> in saturation.

## Outline Drawing, SSPA

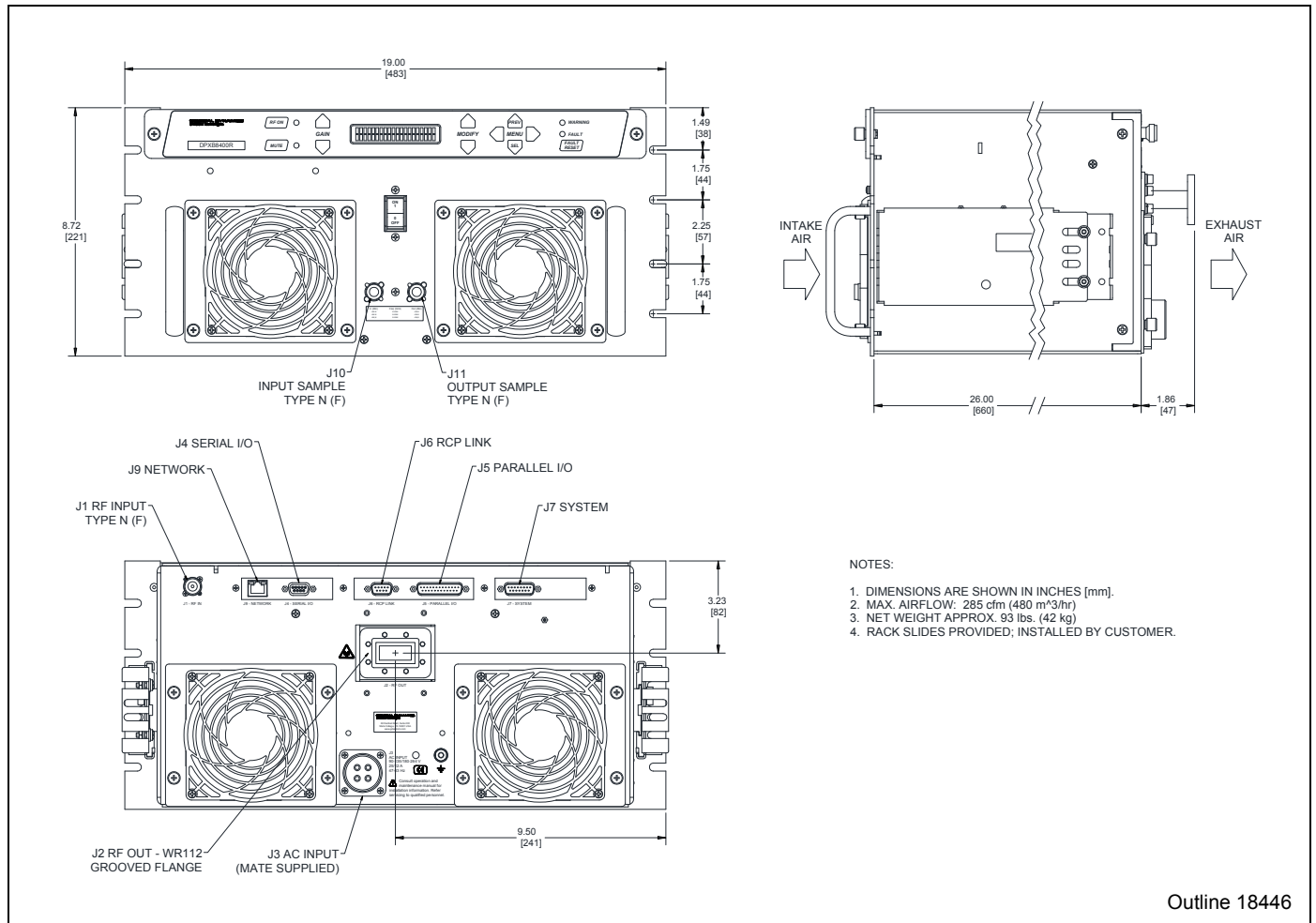

Outline 18446

## Connector Interface

Ref. Des.	Function	Connector Type	Mating Connector	Comment
J1	RF Input	Type N Female	Type N Male	
J2	RF Output	CPR112G Waveguide	CPR112 Flange	
J3	AC In	4-pos CE05, Male	4-pos MS or CE05, Female	Mate supplied
J4	Serial I/O	9-pos D-sub, Female	9-pos D-sub, Male	Mate supplied
J5	Parallel I/O	25-pos D-sub, Male	25-pos D-sub, Female	Mate supplied
J6	RCP Link	9-pos D-sub, Male	9-pos D-sub, Female	
J7	System	15-pos D-sub, Male	15-pos D-sub, Female	
J9	Network	RJ-45 Jack	RJ-45 Plug	
J10	Input Sample	Type N Female	Type N Male	Front panel mounted
J11	Output Sample	Type N Female	Type N Male	Front panel mounted

