

1:1 C-Band Redundant Block Downconverter Systems

Introduction

The VertexRSI BRC-1101 Series C-Band Redundant Block Downconverter (BDC) Systems contain two converters in a 1:1 redundant configuration, including automatic switchover logic, redundant power supplies, and redundant AC line inputs. The systems are designed for installation at satellite earth stations in standard 19-inch EIA equipment racks. The systems are designed to house VertexRSI BDC-3442 C-band block downconverters.

Features

- Standard 19" rack panel, 3½" high
- Dual redundant power supplies
- Worldwide AC input capability
- Monitors converter bias currents to detect faults
- Manual or automatic operation
- Manual override switch control knob on rear panel

Options

- Offline I/O
- Remote panel

Block Diagram

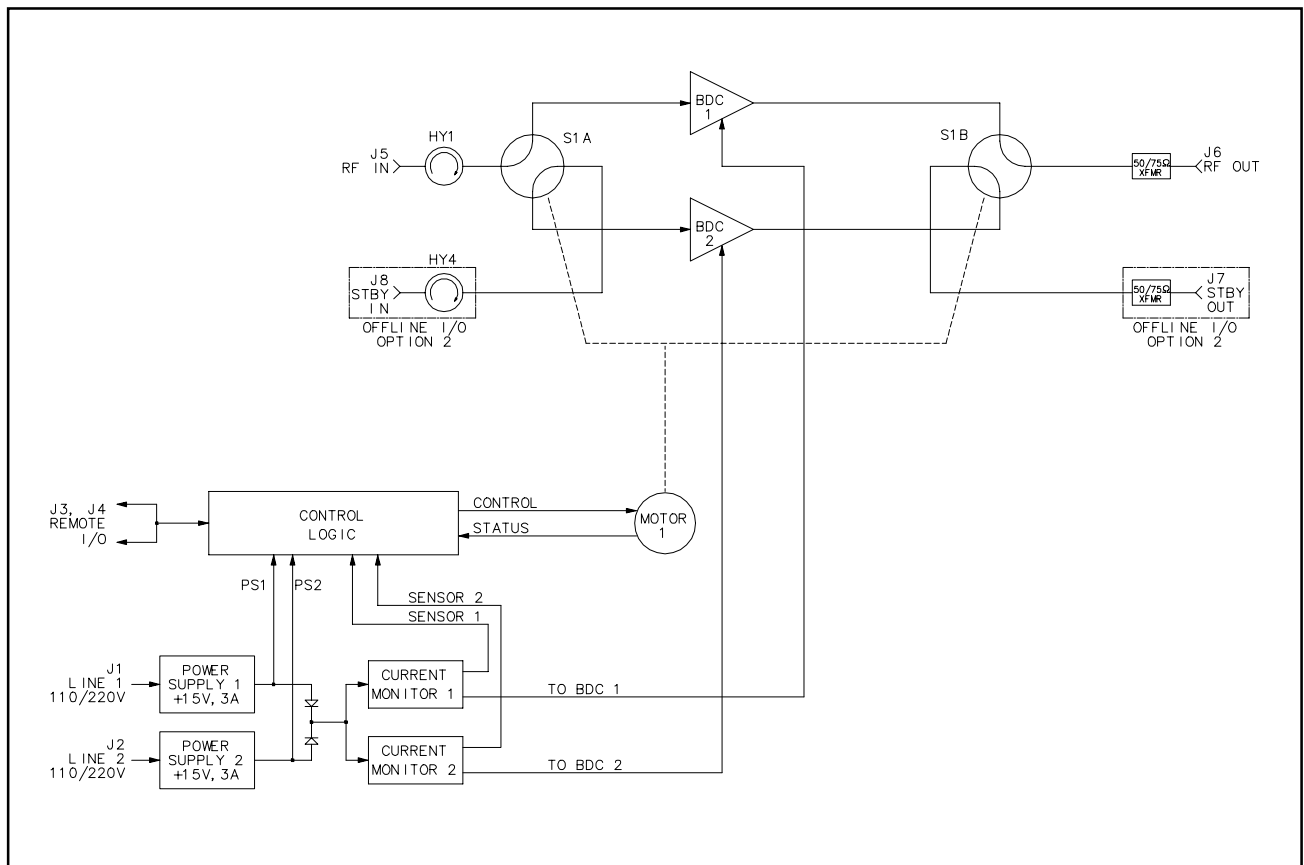

Operating Modes

- **Automatic Mode**

In Automatic mode, if a failure is detected in the on-line converter, the standby converter is switched on-line; switchover is accomplished in 100 milliseconds. The unit will not switch to a defective converter.

- **Manual Mode**

The converters can also be manually switched from the front panel or remotely. In Manual mode, automatic switching will not occur upon fault detection, although the monitor and alarm circuits still function.

Local or Remote Control

The system includes provision for remote status monitoring and operation. Typical uses are for sending status information to a centralized monitor and control system or for remotely controlling the system from a nearby building. All of the Local front panel features can be remotely controlled and monitored (except for the Remote/Local switch). In Remote mode, the front panel switches and pushbuttons are inoperative, but the indicators continue to reflect the current operating state of the system. Remote status outputs are Form 'C' dry relay contacts capable of switching up to 100 Vdc at 0.5 A. Remote control inputs are optoisolator coupled for noise and common mode ground loop rejection.

Front and Rear Panels

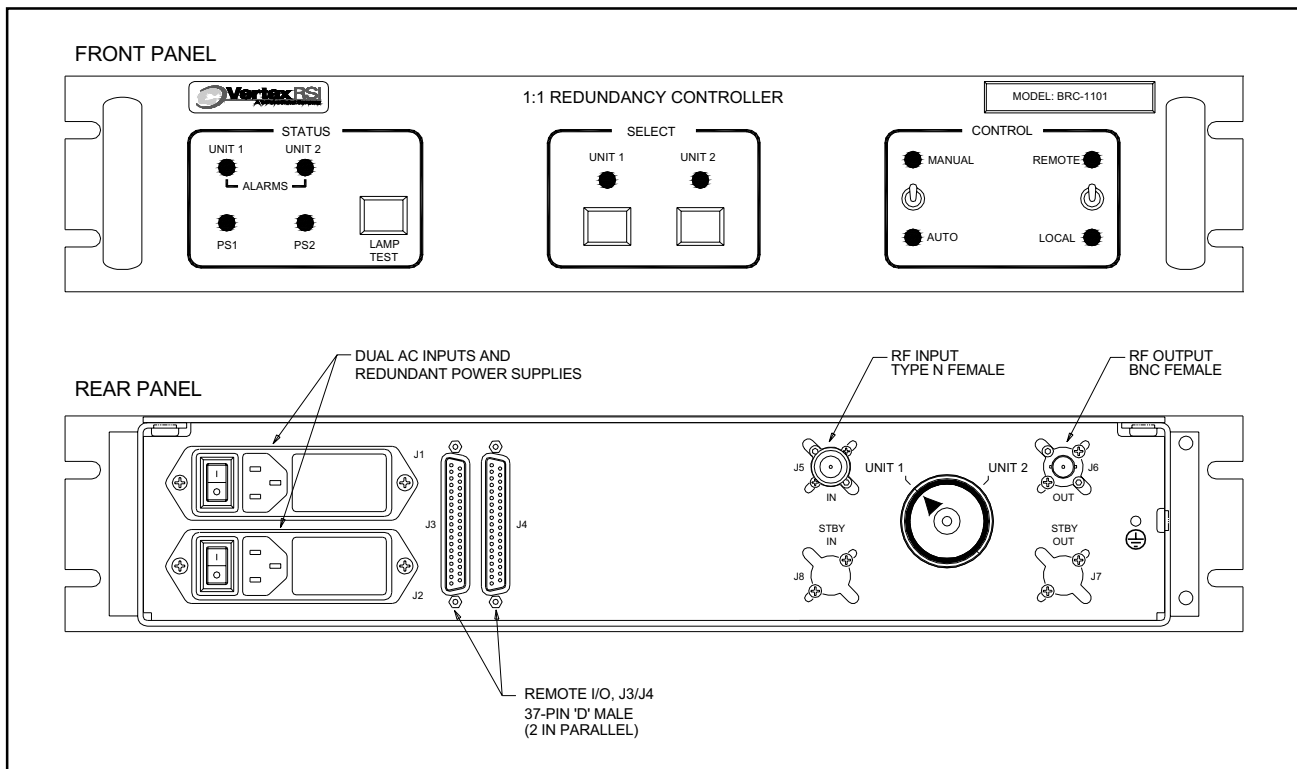

System Specifications *

BRC-1101 Series

Parameter	Notes	Min	Nom/Typ†	Max	Units
Configuration		1:1, One standby block downconverter for one main block downconverter			
Frequency Range	Input	3.40		4.20	GHz
	Output	0.950		1.750	GHz
System Gain	BDC-3442 (Standard)	10	12		dB
	BDC-3442 w/ Option 2	20	22		dB
Gain Flatness	Full band		±1.0	±1.5	dB
Noise Figure	At +23 °C		14	16	dB
Power Output	At 1 dB compression	+8	+10		dBm
Third Order Intercept	Output, OIP ₃	+18	+20		dBm
Local Oscillator Frequency	Internal to BDC		5.150		GHz
Local Oscillator Stability	Over temperature		±12	±15	kHz
Phase Noise	@ 100 Hz offset			-60	dBc/Hz
	@ 1 kHz offset			-70	dBc/Hz
	@ 10 kHz offset			-80	dBc/Hz
	@ 100 kHz offset			-90	dBc/Hz
VSWR	Input (50 ohms)		1.20	1.25	:1
	Output (75 ohms)		1.5	2.0	:1
Connectors	RF input RF output Remote I/O	Type N Female Type BNC Female (75 ohms) 37-pin D Male (2 in parallel)			
Operating Modes		Manual or Automatic			
Alarm Method		BDC phase lock/bias current. Alarm is generated if current goes outside of current window.			
Window Width	Jumper selectable	±5 mA to ±25 mA in 5 mA steps			
Remote I/O	Form 'C' contacts	100 Vdc/250 mA			
	Control inputs	Contact closure to ground; withstand 15 V, sink 10 mA			
Power Requirements	Voltage	-13%	100/120/220/240	+10%	Vac
	Frequency	47		63	Hz
	Power		30		W
Size			19 x 3.47 x 22		inches
			483 x 88.1 x 559		mm
Temperature Range	Operating	0		+50	°C

* System specifications depend on choice of BDC and various options. Specifications shown are for VertexRSI BDC-3442.

† When there is only one value on a line, this column is a nominal value. Otherwise it is a typical value. Typical values are intended to illustrate typical performance, but are not guaranteed.

Part Number/Ordering Information

BRC-1101-

Assigned by factory
at time of order.

BDC Model Number: BDC-3442
(See BDC-3442 Series specification sheet.)

Option 2: Offline I/O
Option 5: Remote panel

OTHER VertexRSI PRODUCTS

- Low Noise Amplifiers and LNA Systems
- Solid-State Power Amplifiers and SSPA Systems
- General Purpose Converters
- Satellite Communications Equipment
- Custom Subsystems



10110 Rev. C 10/18/01
Specifications are subject to change at VertexRSI's discretion.